

ADDENDUM NO. 1
09/27/2024

PROJECT: CITY OF SUDAN
SIDEWALK IMPROVEMENTS

BID DATE: October 4, 2024

The following changes and/or additions shall be made to the Plans, Specifications, and Contract Documents for the above referenced project. Bidder shall acknowledge receipt of this Addendum by signing below and returning this Addendum with the Bid.

1) CONTRACT DOCUMENTS

- a) **Bid Schedule – A new bid schedule has been issued that includes pavement repair items which are being included to establish a unit price. While pavement repair of the area outside of the new curb and gutter is not expected, these items are being included in the event that pavement repair is needed due to unforeseen circumstances.**

2) PLAN SHEETS

Sheet 19- Sheet 19 has been modified to include details on Asphalt Repair.

Prepared by:

JACOB | MARTIN
TBPE Firm No. 2448

Bidder's Acknowledgment

Date

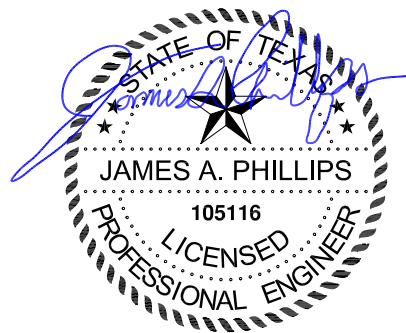

09/27/2024

**CITY OF SUDAN
SIDEWALK IMPROVEMENTS
BASE BID SCHEDULE - ADDENDUM #1**

Show prices in numerals. Round off unit prices to two decimal places only.
These Bid Prices must include all labor, materials, equipment, insurance, overhead, superintendence, transportation, taxes, permits, profits & incidentals to cover the finished Work called for in the Contract Documents.

For all Labor, Materials, Equipment and Incidentals to Furnish and Install the Following:

Bid Item	Description	Est. Qty.	Unit	Unit Price	Extended Amount
Area #1 - West Side of Main (W 2nd to W 1st)					
1	Mobilization	1	LS	\$	\$
2	4" Concrete Sidewalk/Flatwork, including Steps	320	SY	\$	\$
3	Concrete Curb and Gutter	378	LF	\$	\$
4	ADA Ramps	304	SF	\$	\$
5	Handrails - Ramp	87	LF	\$	\$
6	Handrails - Step Rails	4	LF	\$	\$
7	Traffic Control	1	LS	\$	\$
Area #1 Subtotal					\$
Area #2 - West Side of Main (W 1st to Hwy 84)					
1	Mobilization	1	LS	\$	\$
2	4" Concrete Sidewalk/Flatwork, including Steps	243	SY	\$	\$
3	Concrete Curb and Gutter	299	LF	\$	\$
4	ADA Ramps	292	SF	\$	\$
5	Handrails - Ramp	96	LF	\$	\$
6	Handrails - Step Rails	17	LF	\$	\$
7	Traffic Control	1	LS	\$	\$
Area #2 Subtotal					\$
Area #3 - East Side of Main (E 2nd to E 1st)					
1	Mobilization	1	LS	\$	\$
2	4" Concrete Sidewalk/Flatwork, including Steps	323	SY	\$	\$
3	Concrete Curb and Gutter	374	LF	\$	\$
4	ADA Ramps	83	SF	\$	\$
5	Handrails - Ramp	0	LF	\$	\$
6	Handrails - Step Rails	0	LF	\$	\$
7	Traffic Control	1	LS	\$	\$
8	6" Concrete Pavement	20	SY	\$	\$
Area #3 Subtotal					\$

TOTAL BASE BID (Area 1 + Area 2 + Area 3)	\$
--	-----------

PROPOSED NUMBER OF DAYS FOR COMPLETION*	DAYS
--	-------------

* Bidder must enter proposed number of days both on the Bid Schedule and on pages BP-1 and BP-3 of the Bid Proposal.

**CITY OF SUDAN
SIDEWALK IMPROVEMENTS
ALTERNATE BID SCHEDULE - ADDENDUM #1**

Show prices in numerals. Round off unit prices to two decimal places only.
These Bid Prices must include all labor, materials, equipment, insurance, overhead, superintendence, transportation, taxes, permits, profits & incidentals to cover the finished Work called for in the Contract Documents.

ADDITIVE ALTERNATE BID SCHEDULE

For all Labor, Materials, Equipment and Incidentals to Furnish and Install the Following:

Bid Item	Description	Est. Qty.	Unit	Unit Price	Extended Amount
A1	Concrete Additive Area #1	434	SY	\$	\$
A2	Concrete Additive Area #2	342	SY	\$	\$
A3	Concrete Additive Area #3	416	SY	\$	\$
A4	HMAC	1	SY	\$	\$
A5	Prime Oil	1	GAL	\$	\$
A6	Flex Base	1	CY	\$	\$
TOTAL ADDITIVE ALTERNATE BID (Items A1-A6)					\$

Note: Concrete Additive Quantity above includes sidewalk and steps as well as ramps and curb and gutter.

DEDUCTIBLE ALTERNATE BID SCHEDULE

For all Labor, Materials, Equipment and Incidentals to Furnish and Install the Following:

Bid Item	Description	Est. Qty.	Unit	Unit Price	Extended Amount
Area #3 - East Side of Main (E 2nd to E 1st)					
D1	Mobilization	1	LS	\$	\$
D2	4" Concrete Sidewalk/Flatwork, including Steps	323	SY	\$	\$
D3	Concrete Curb and Gutter	374	LF	\$	\$
D4	ADA Ramps	83	SF	\$	\$
D5	Handrails - Ramp	0	LF	\$	\$
D6	Handrails - Step Rails	0	LF	\$	\$
D7	Traffic Control	1	LS	\$	\$
D8	6" Concrete Pavement	20	SY	\$	\$
TOTAL DEDUCTIBLE ALTERNATE BID (Items D1-D8)					\$

Note: Owner reserves the right to accept any combination of base bid and additive alternate bid items.

X:\C_Sudan\22533-2023 DRP Sidewalk Improvements - City of Sudan\Drafting\Plans\C_Civ\19 SIDEWALK DETAILS.dwg
 Saved By: ophillips
 Save Time: 9/4/2024 6:55 PM
 Plotted by: allen_phillips
 Plot Date: 9/27/2024 11:15 AM



ISSUED FOR BID

JACOB MARTIN

TBPE FIRM # 2446
 TBFAE FIRM # BR 2261
 TBPELS FIRM # 10194453

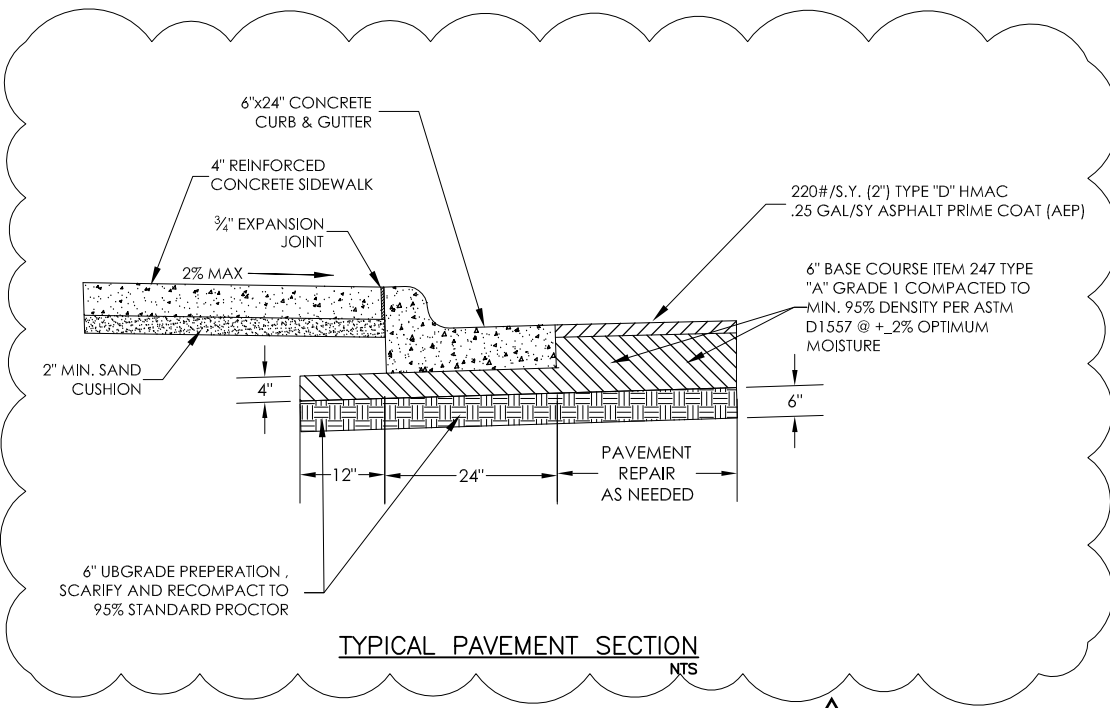

TYPICAL PAVEMENT SECTION
NTS

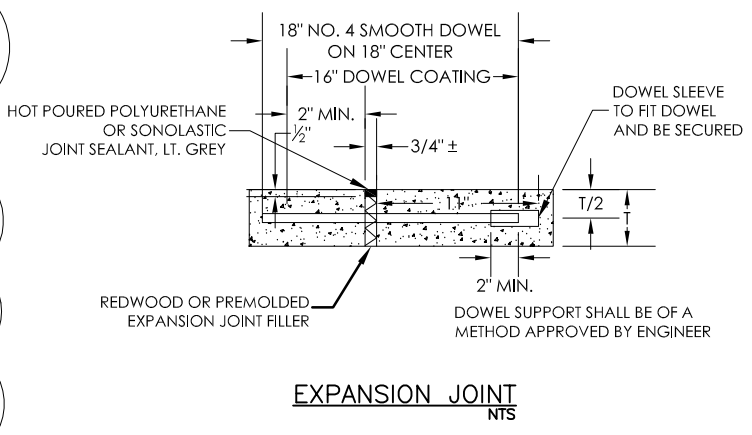

EXPANSION JOINT
NTS

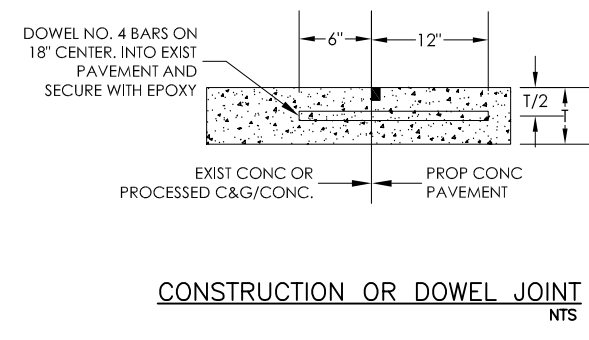

CONSTRUCTION OR DOWEL JOINT
NTS

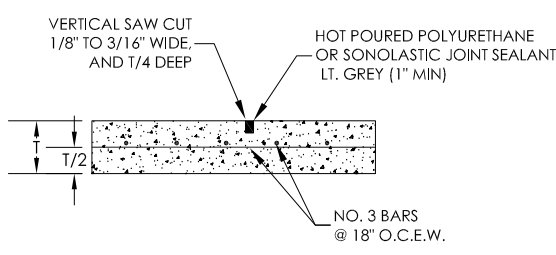

SAWED DUMMY JOINT
NTS

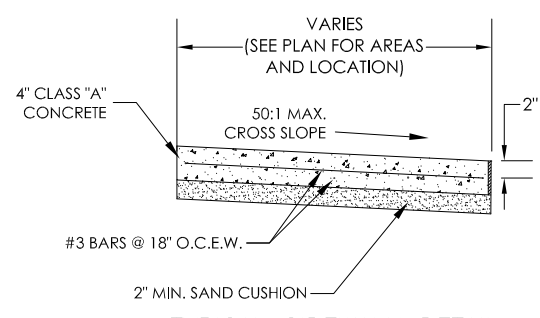

TYPICAL SIDEWALK DETAIL
NTS

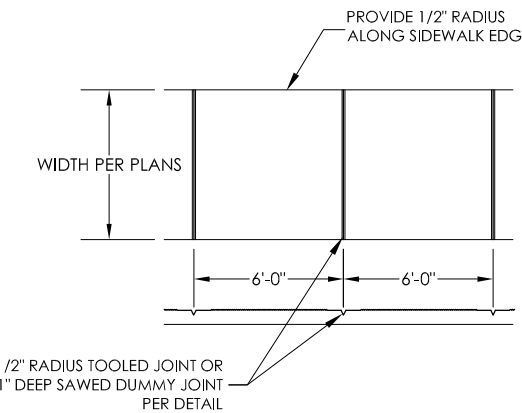

SIDEWALK FINISH DETAIL
NTS

- NOTES:
- NO GRATINGS, ACCESS COVERS OR APPURTENANCES WITHIN CURB RAMPS.
 - ALL SUBGRADE SHALL BE COMPACTED TO 95% PROCTOR DENSITY.
 - PROVIDE 3/4" EXPANSION JOINTS BETWEEN SIDEWALKS AND ALL FIXED OBJECTS.
 - SIDEWALK CROSS SLOPES SHALL NOT EXCEED 2% AND RUNNING SLOPES SHALL NOT EXCEED 5%.
 - RAMPS SHALL NOT EXCEED 2% ACROSS SLOPE AND 8.33% RUNNING ON RAMP SLOPE.

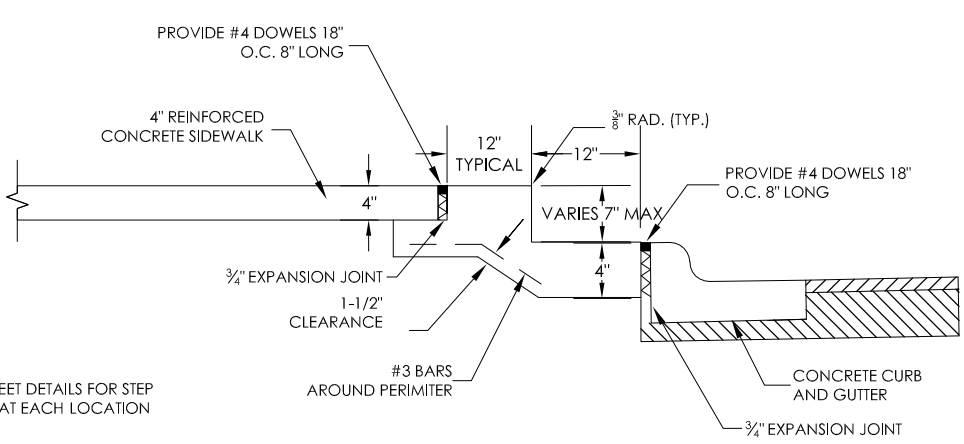

NOTE:
1. SEE PLAN SHEET DETAILS FOR STEP DIMENSIONS AT EACH LOCATION

SIDEWALK STEPS
NTS

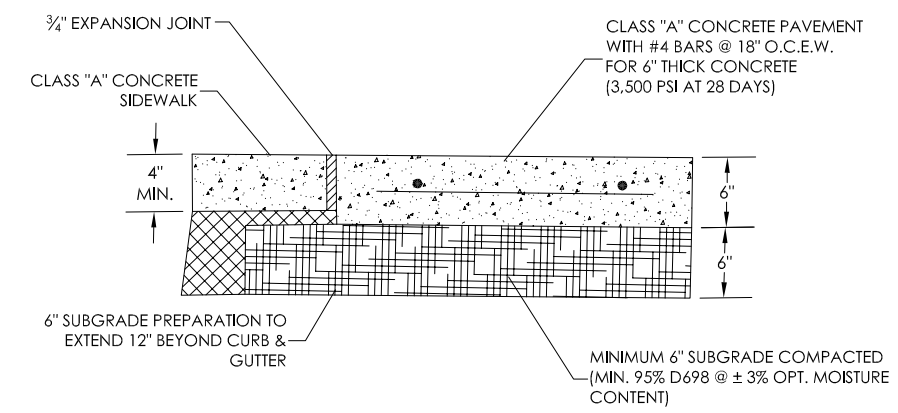

6" CONCRETE PAVEMENT SECTION
NTS

CITY OF SUDAN
 TDA SIDEWALK IMPROVEMENTS
 SIDEWALK DETAILS

NO.	REVISION	DATE
1	Addendum #1	09/27/2024
SEQ.	SHEET	
19	22	19

PROJECT # 22533
 SCALE NTS
 BAR IS ONE INCH IN LENGTH ON ORIGINAL DRAWING.
 CHECK SCALE AND ADJUST ACCORDINGLY.